

# Appendix “E” – Fence Details

---

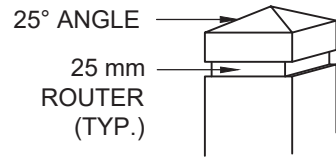

TYPICAL POST CAP DETAIL

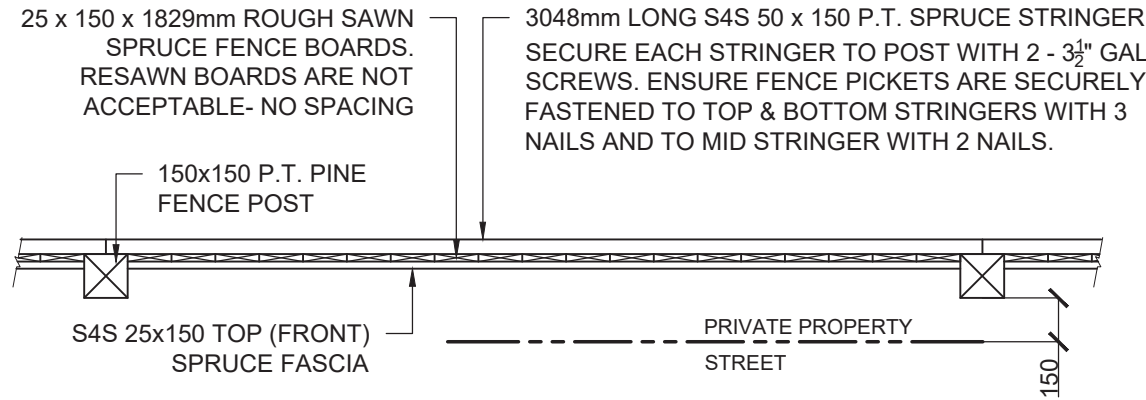

PLAN

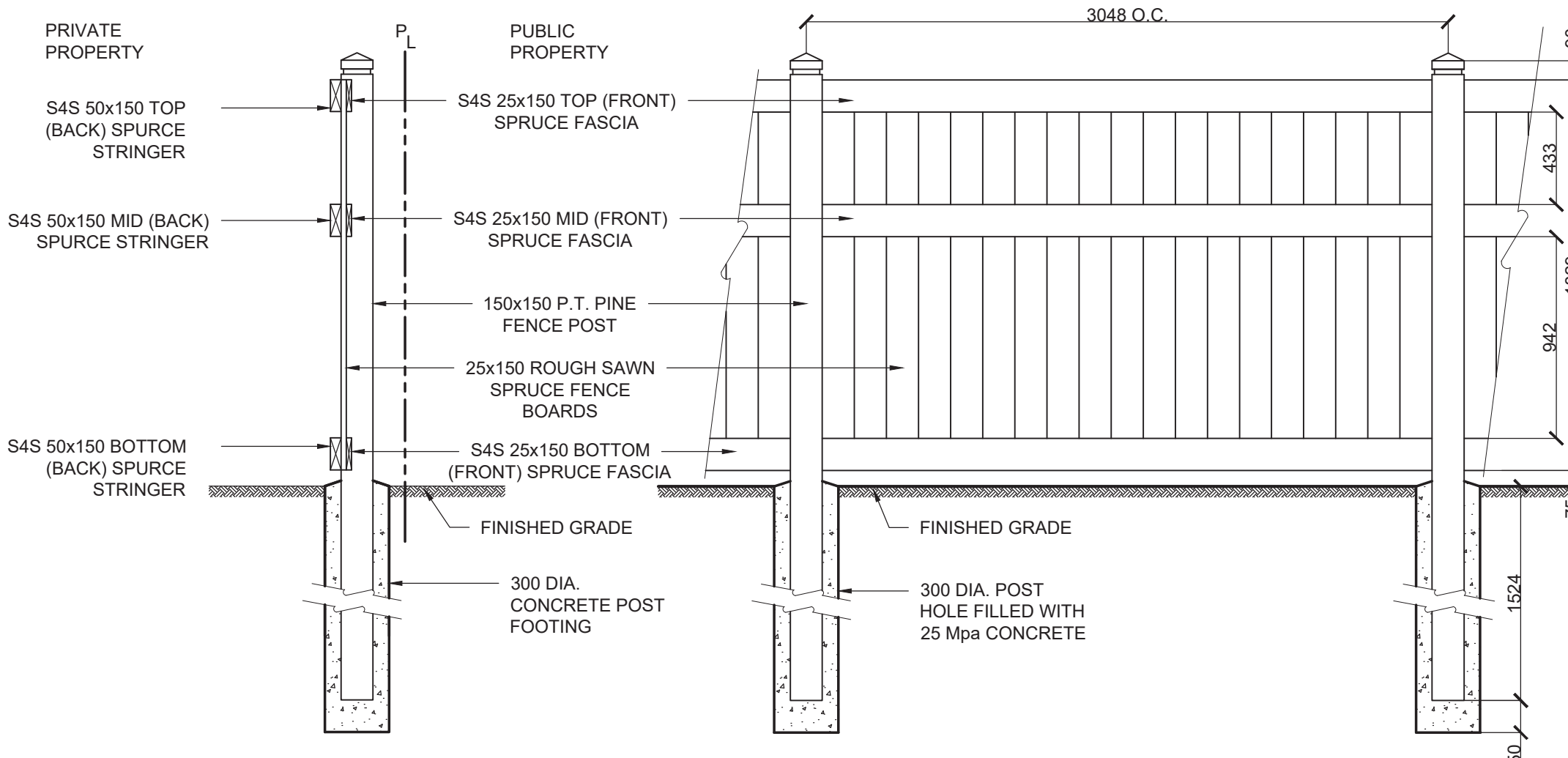

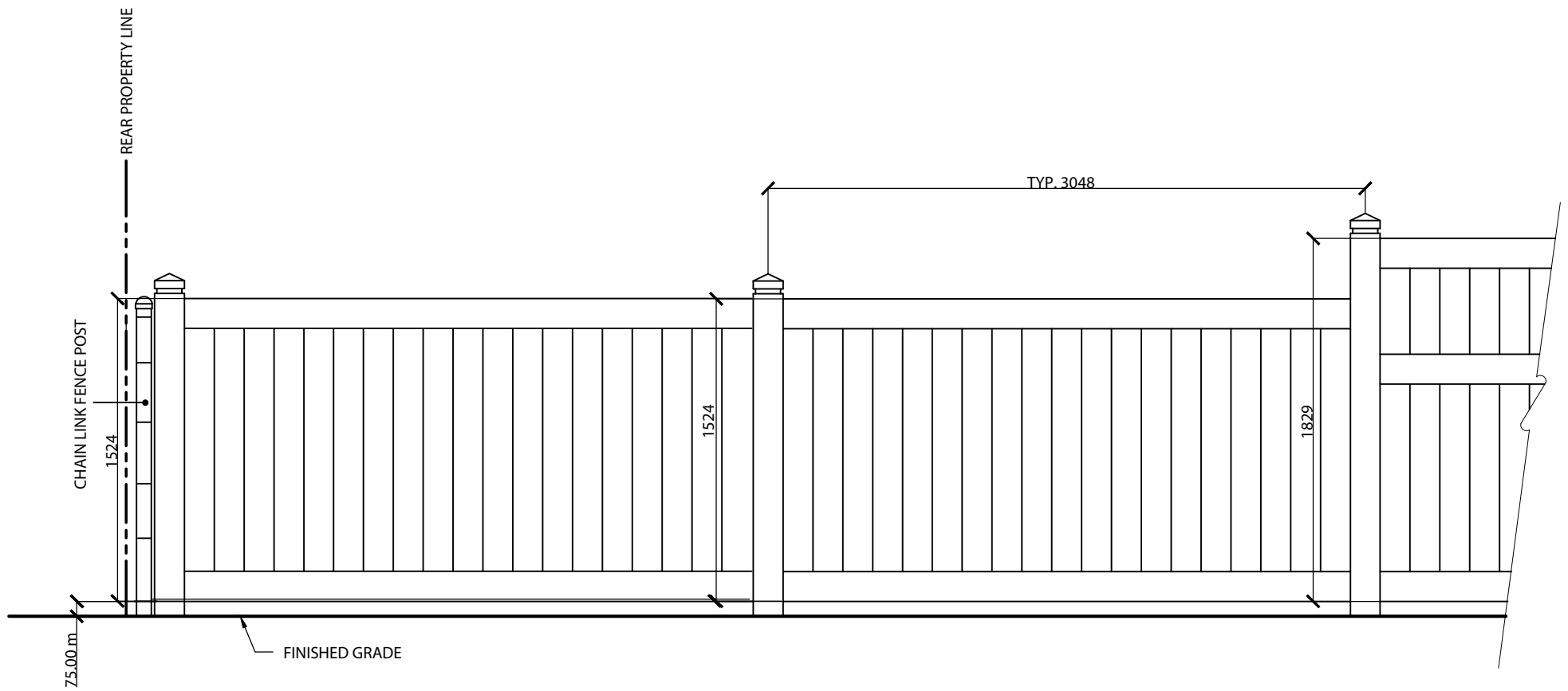

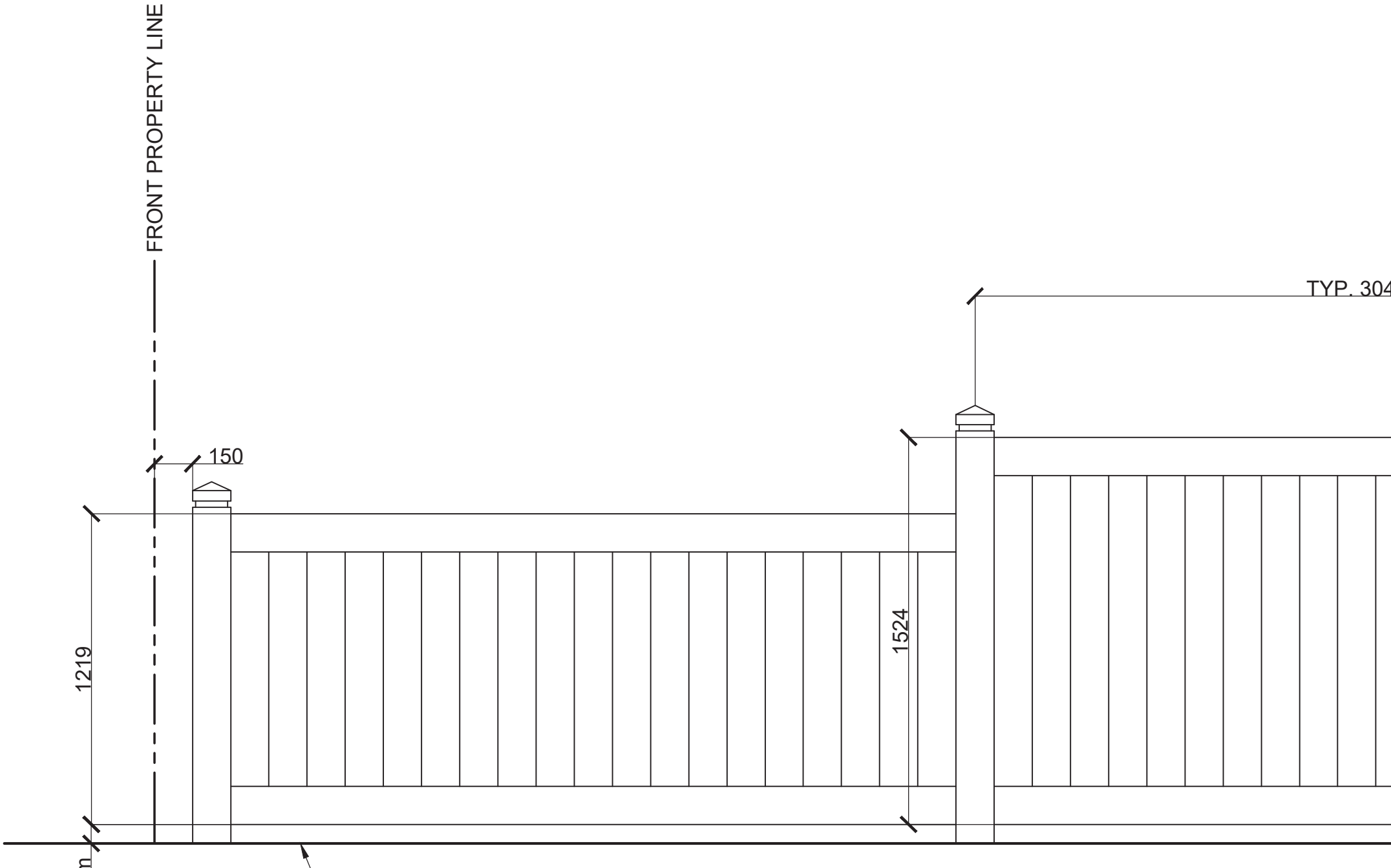

FRONT PROPERTY LINE

TYP. 304

150

1219

1524

m

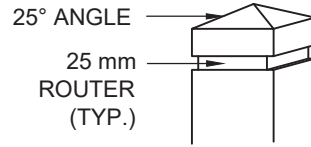

TYPICAL POST  
CAP DETAIL

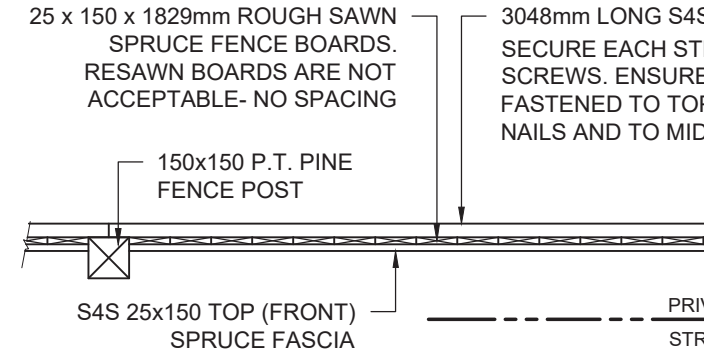

PLAN

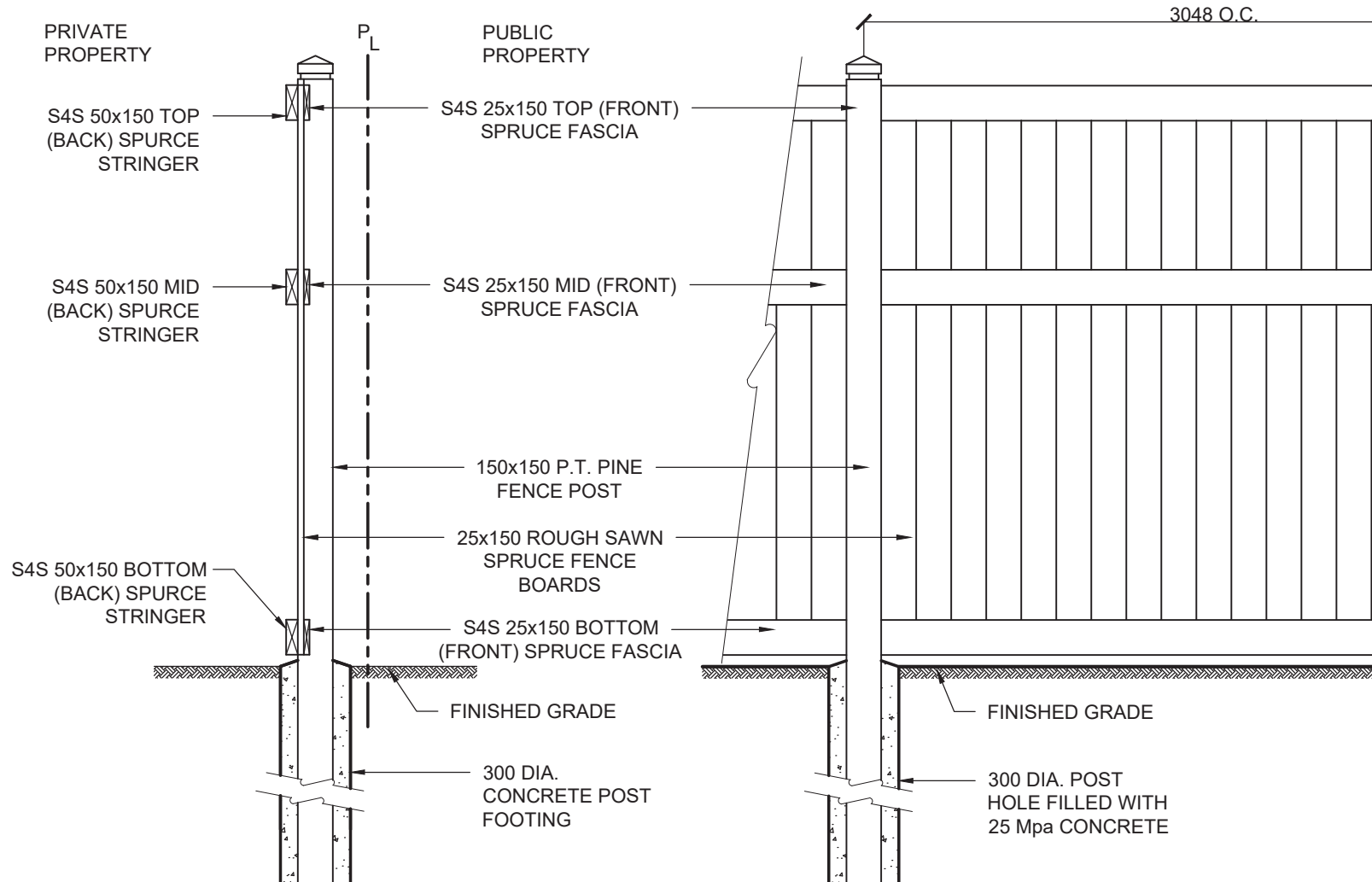

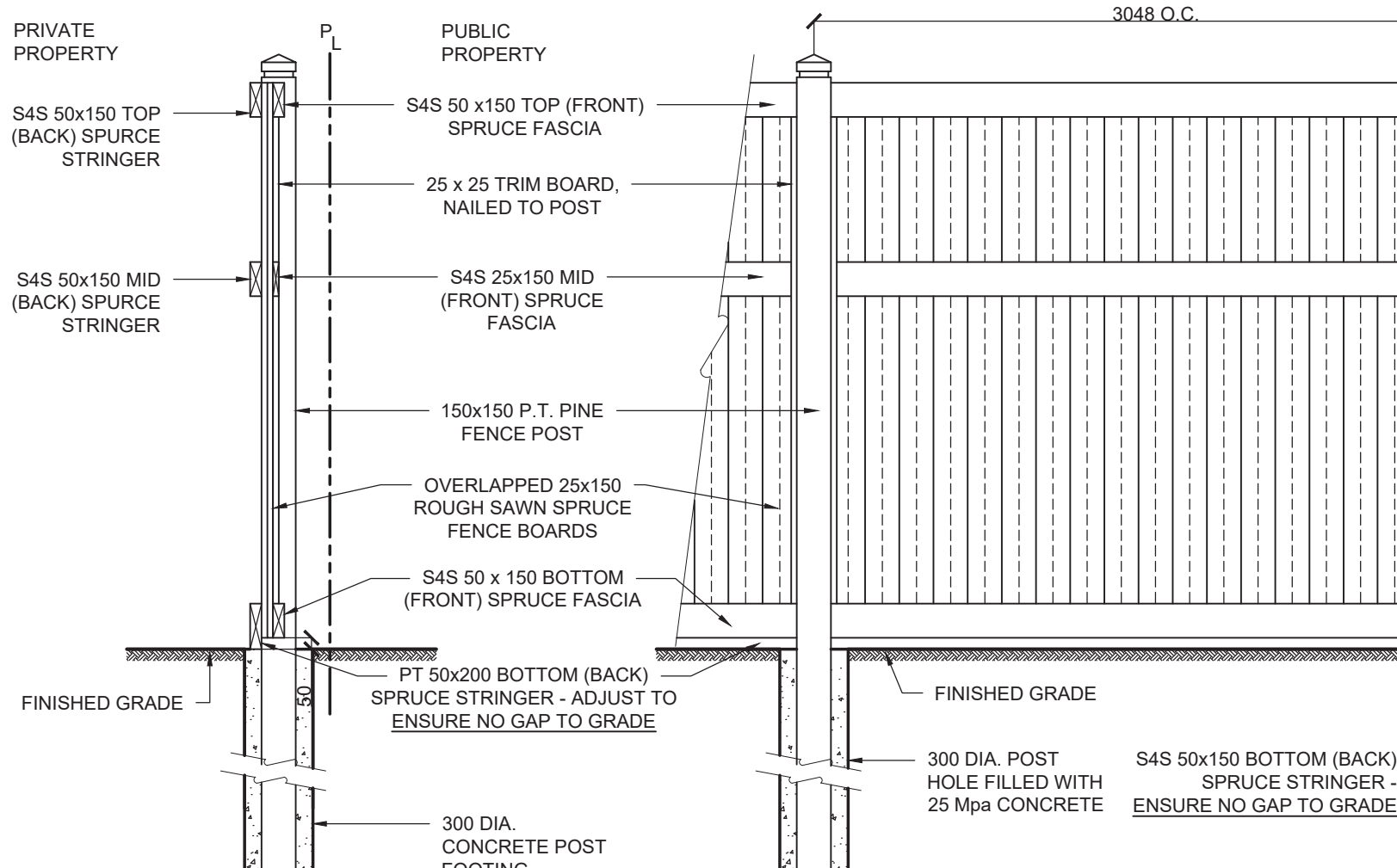
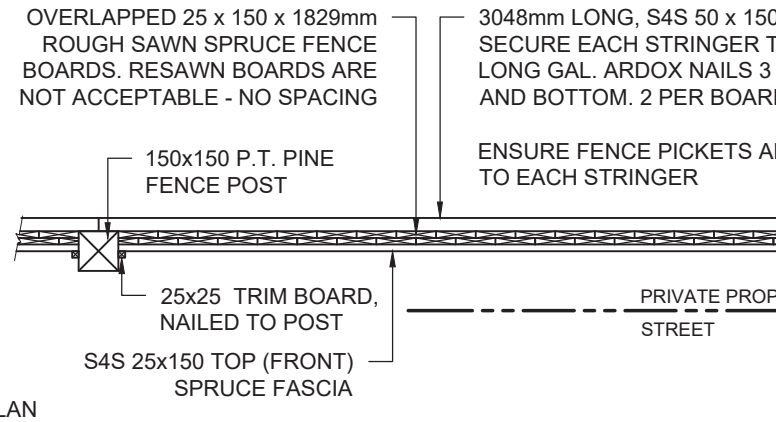

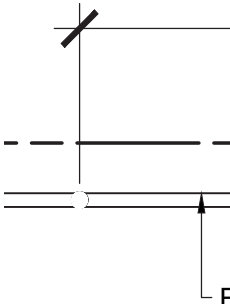
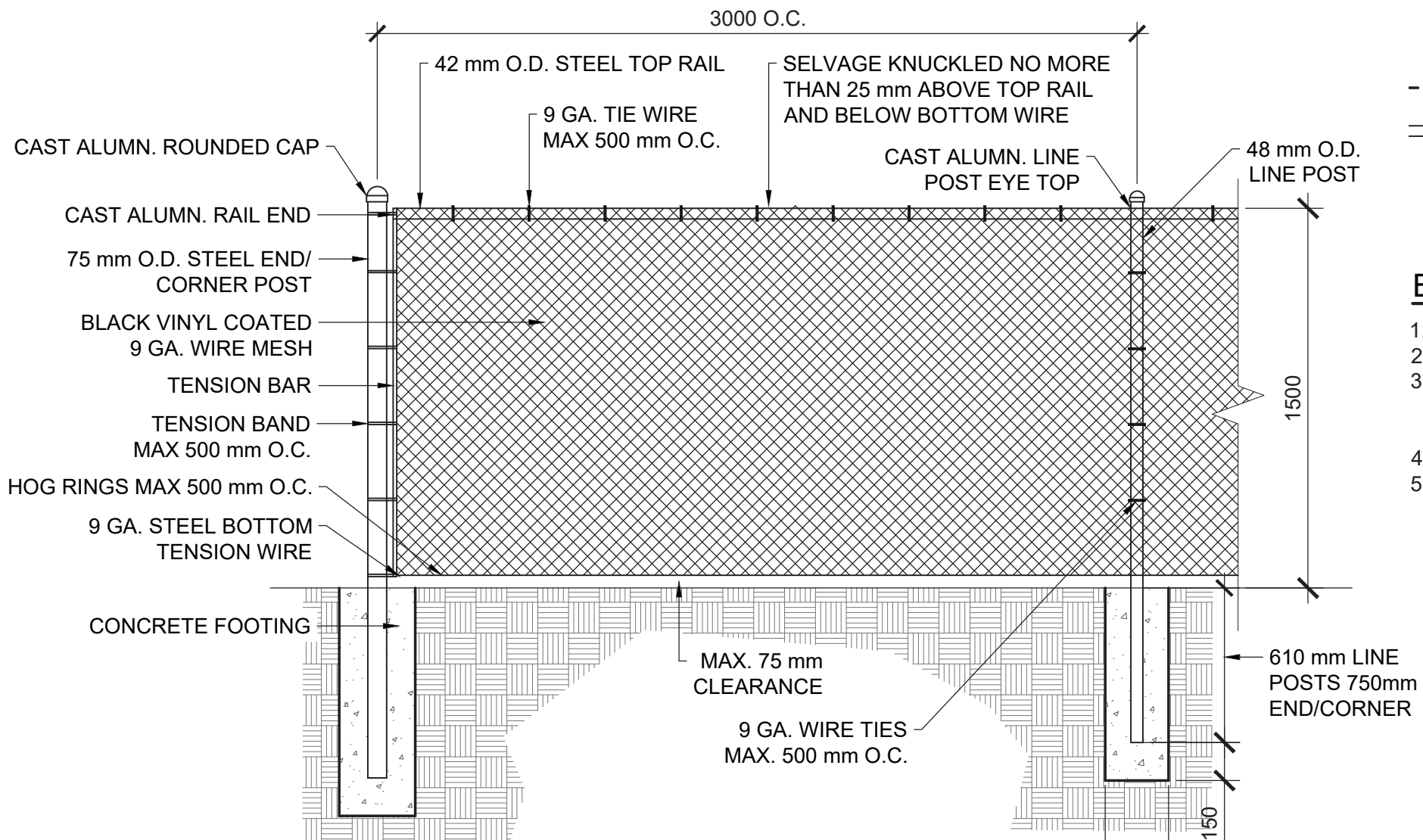

**BLACK CHAIN LINK FENCE**

1. DIMENSIONS
2. GATE FRAME
3. CONCRETE
- AT 28 DAYS
- AGGREGATE
4. FENCE TO B
5. ALL COMPO

# Appendix “E” – Fence Details

---



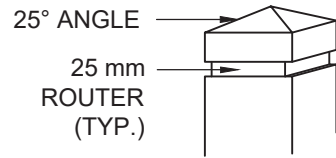

TYPICAL POST CAP DETAIL

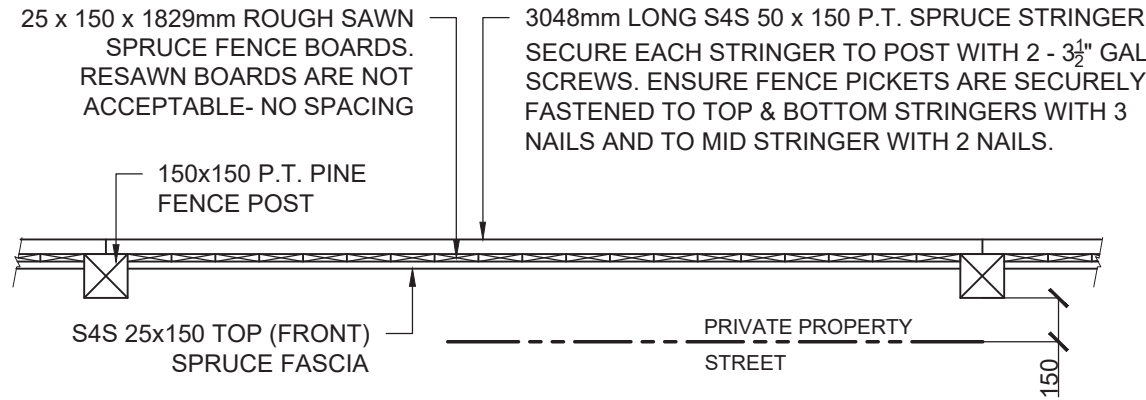

PLAN

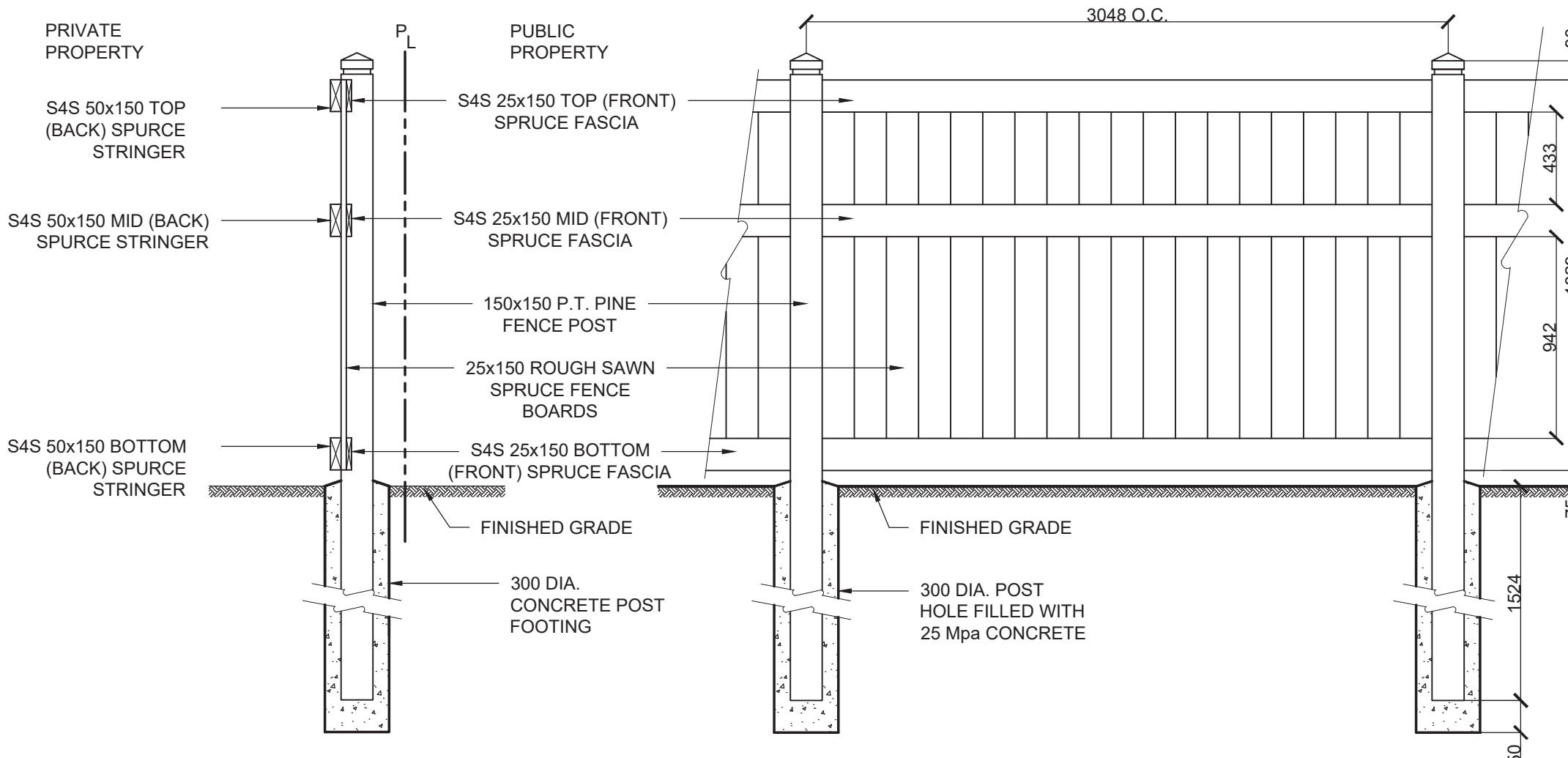

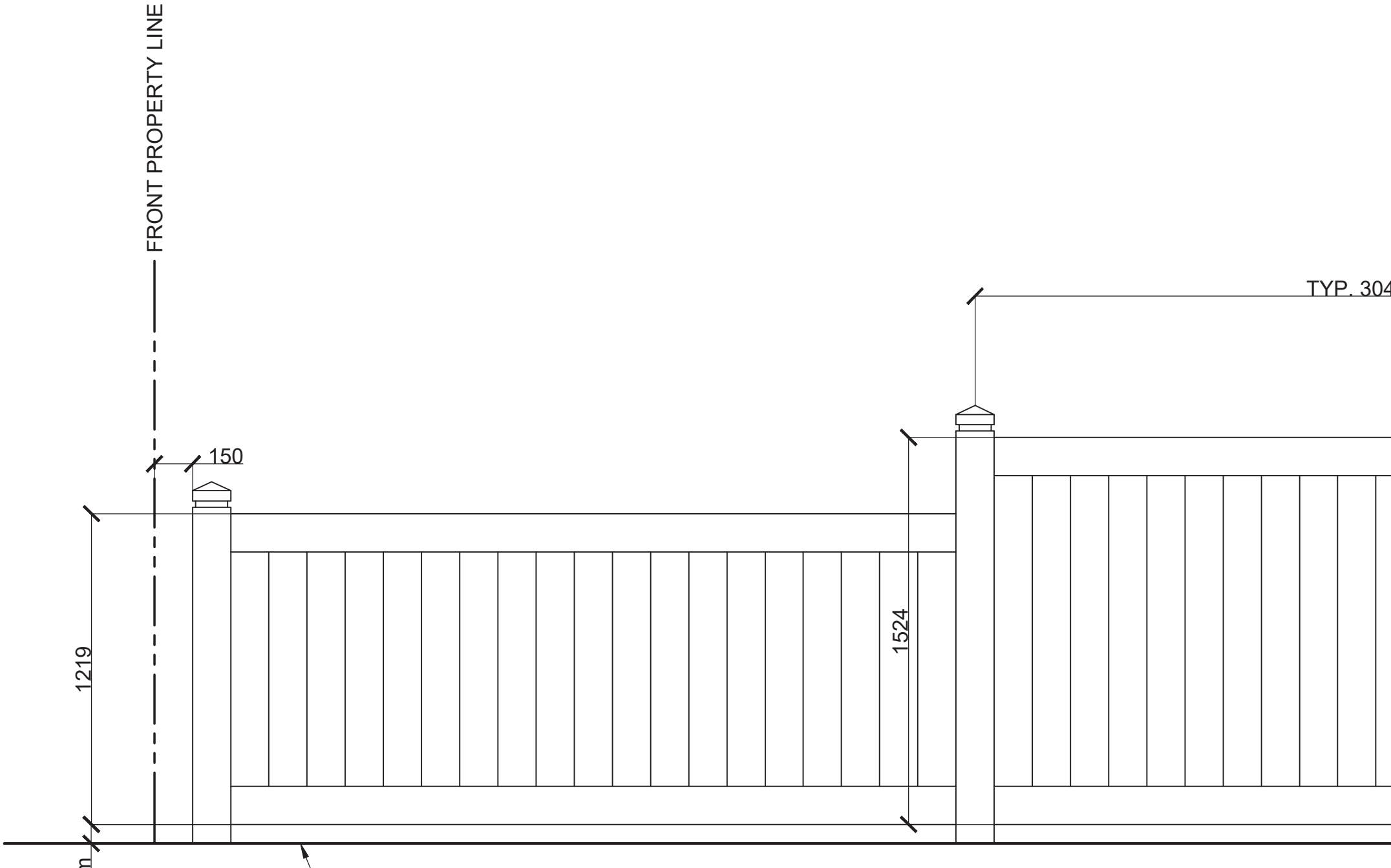

FRONT PROPERTY LINE

1219

150

1524

TYP. 304

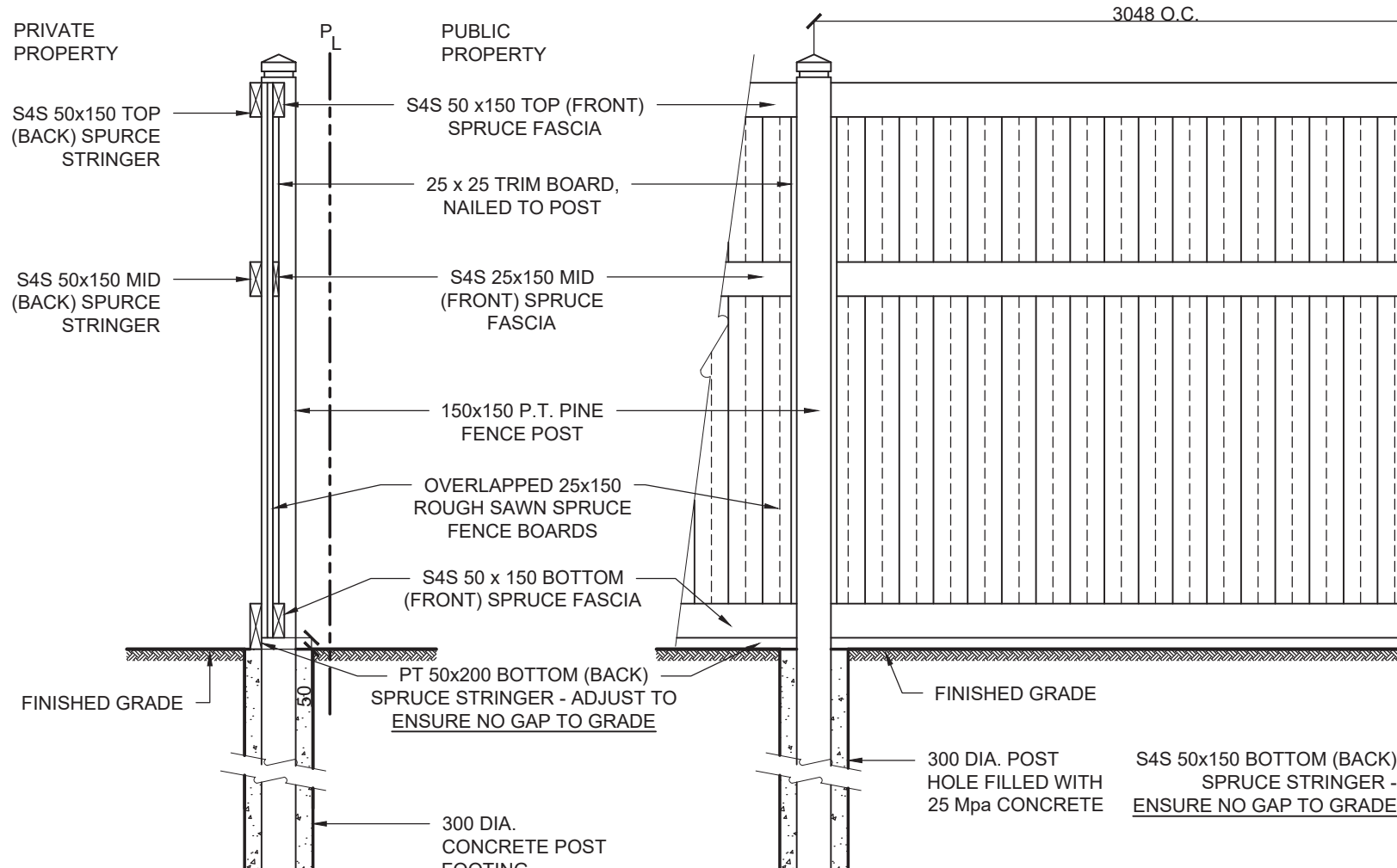
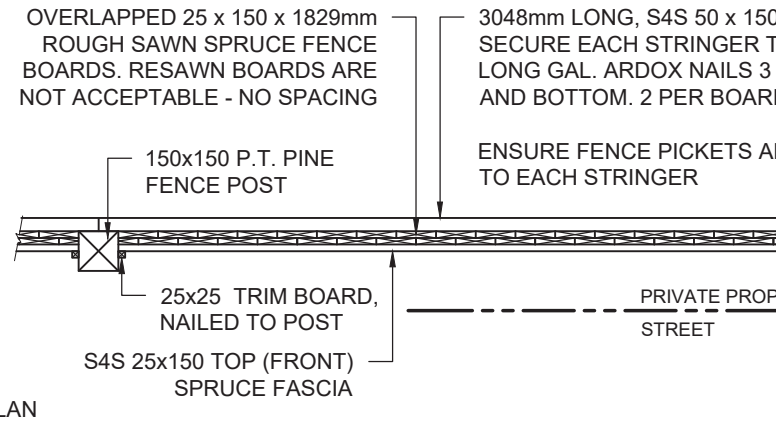

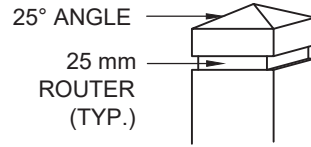

TYPICAL POST  
CAP DETAIL

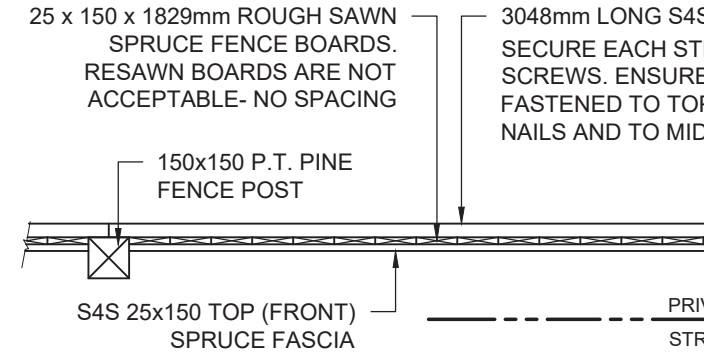

PLAN

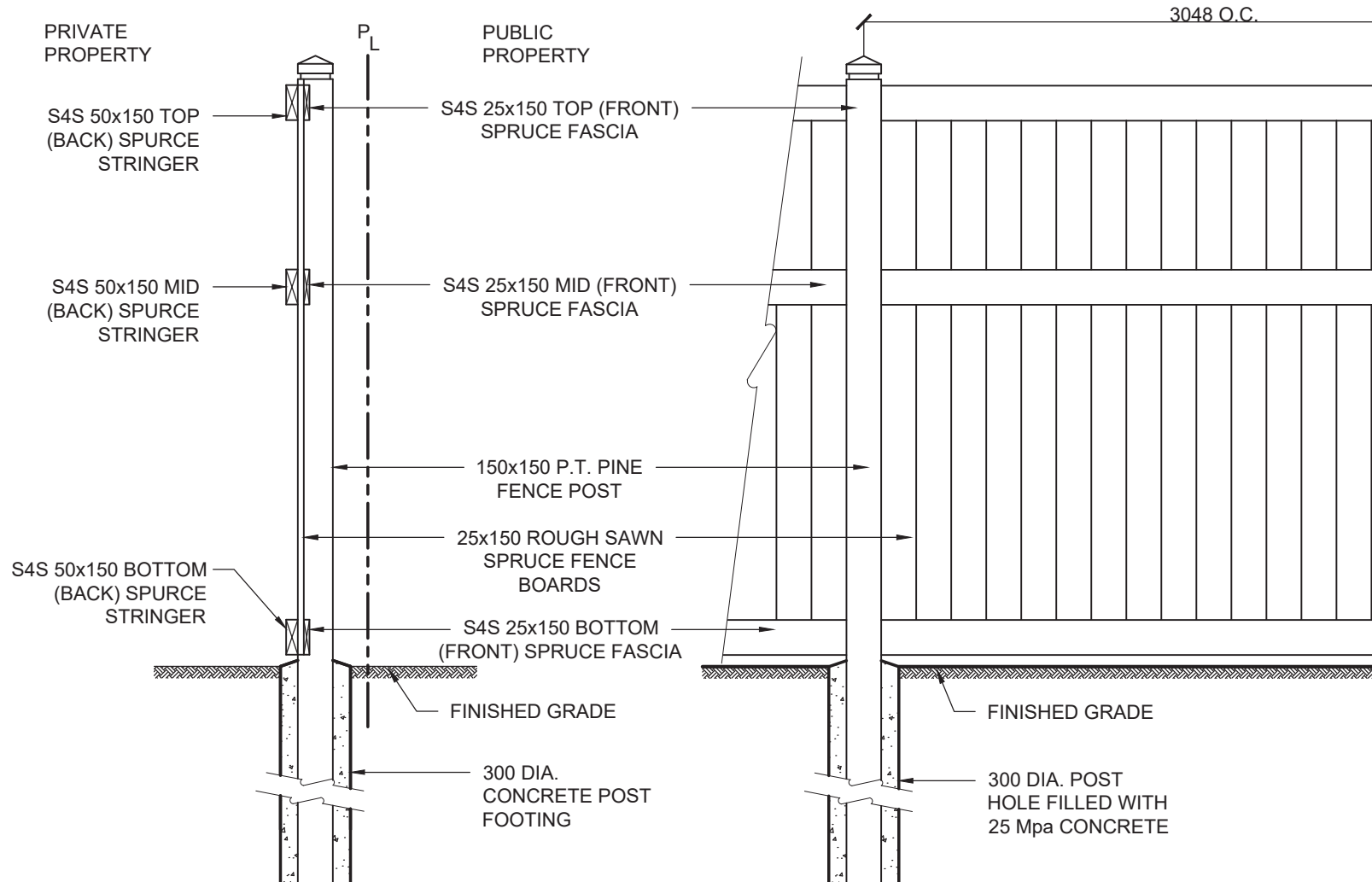

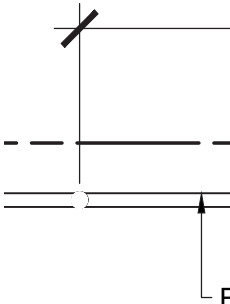
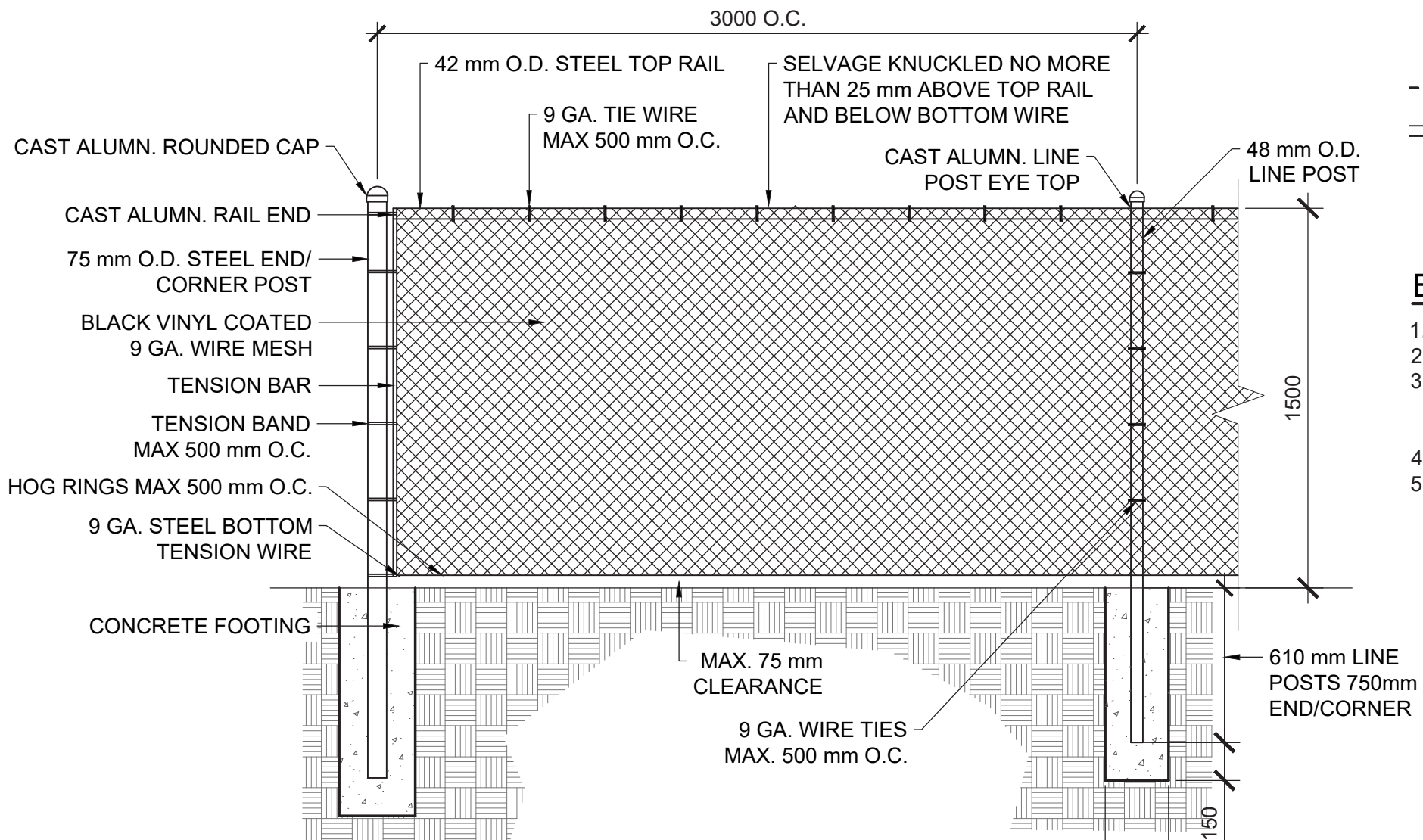

**BLACK CHAIN LINK FENCE**

1. DIMENSIONS
2. GATE FRAME
3. CONCRETE
- AT 28 DAYS
- AGGREGATE
4. FENCE TO B
5. ALL COMPO

# Appendix “E” – Fence Details

---

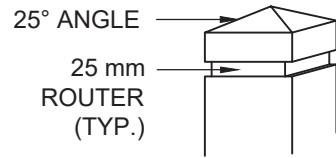

TYPICAL POST CAP DETAIL

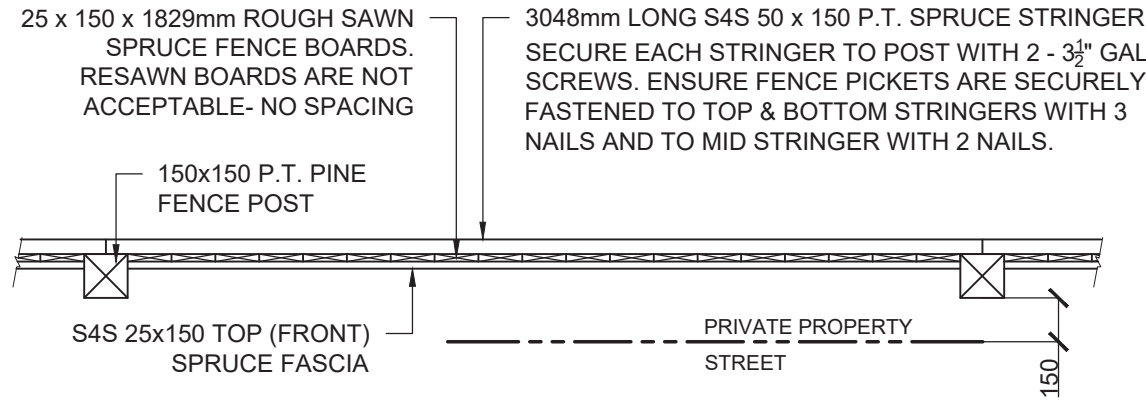

PLAN

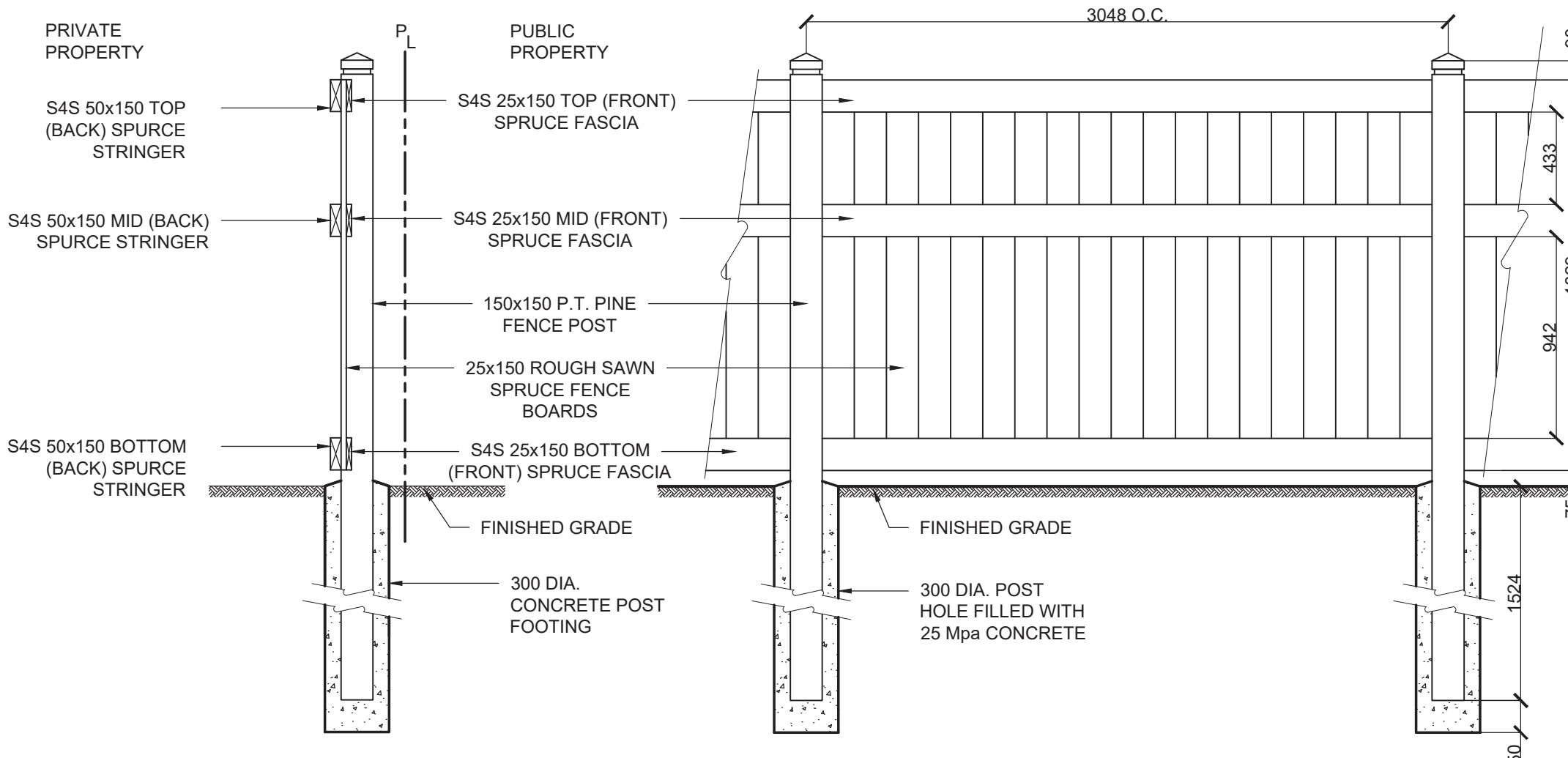

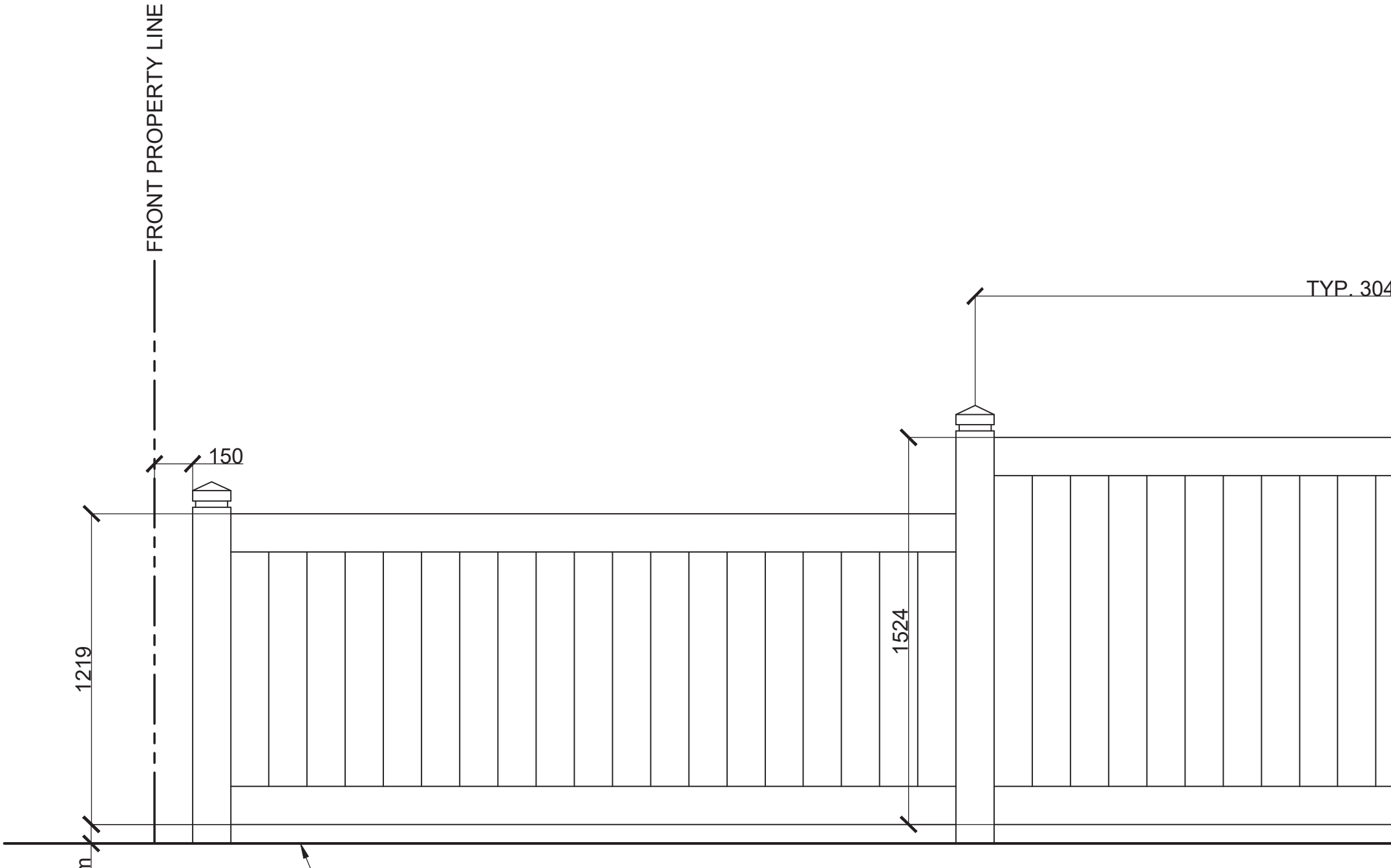

FRONT PROPERTY LINE

TYP. 304

150

1219

1524

m



# Appendix “E” – Fence Details

---

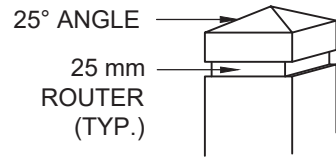

TYPICAL POST CAP DETAIL

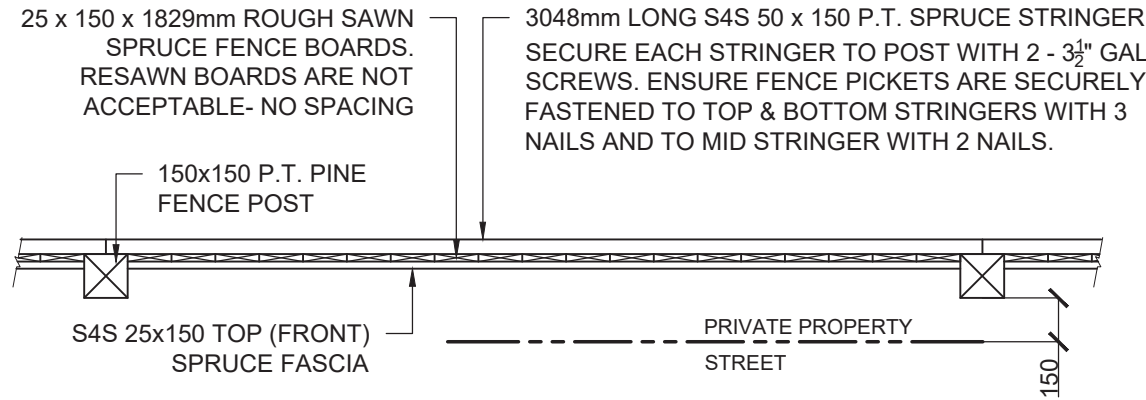

PLAN

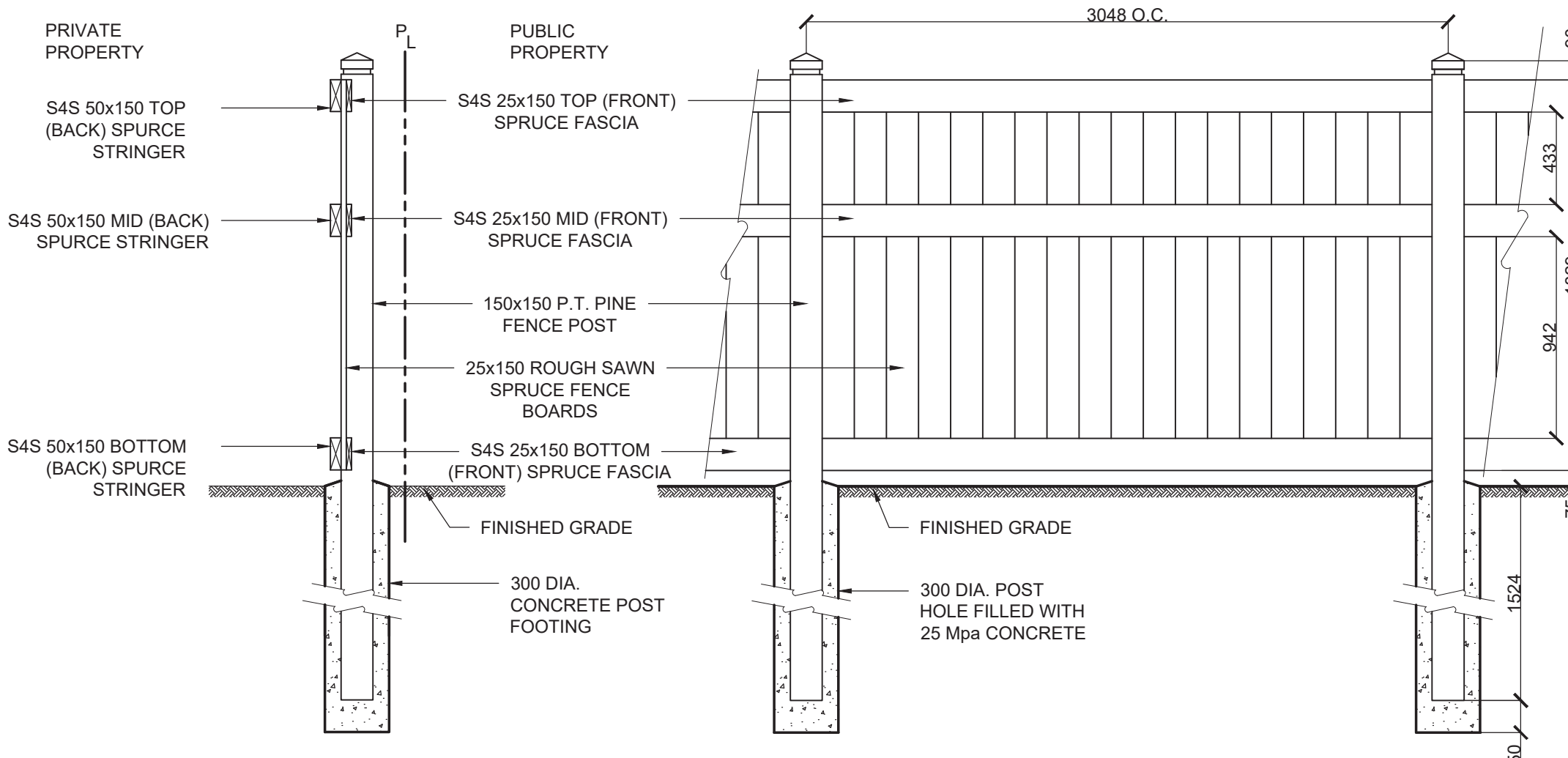

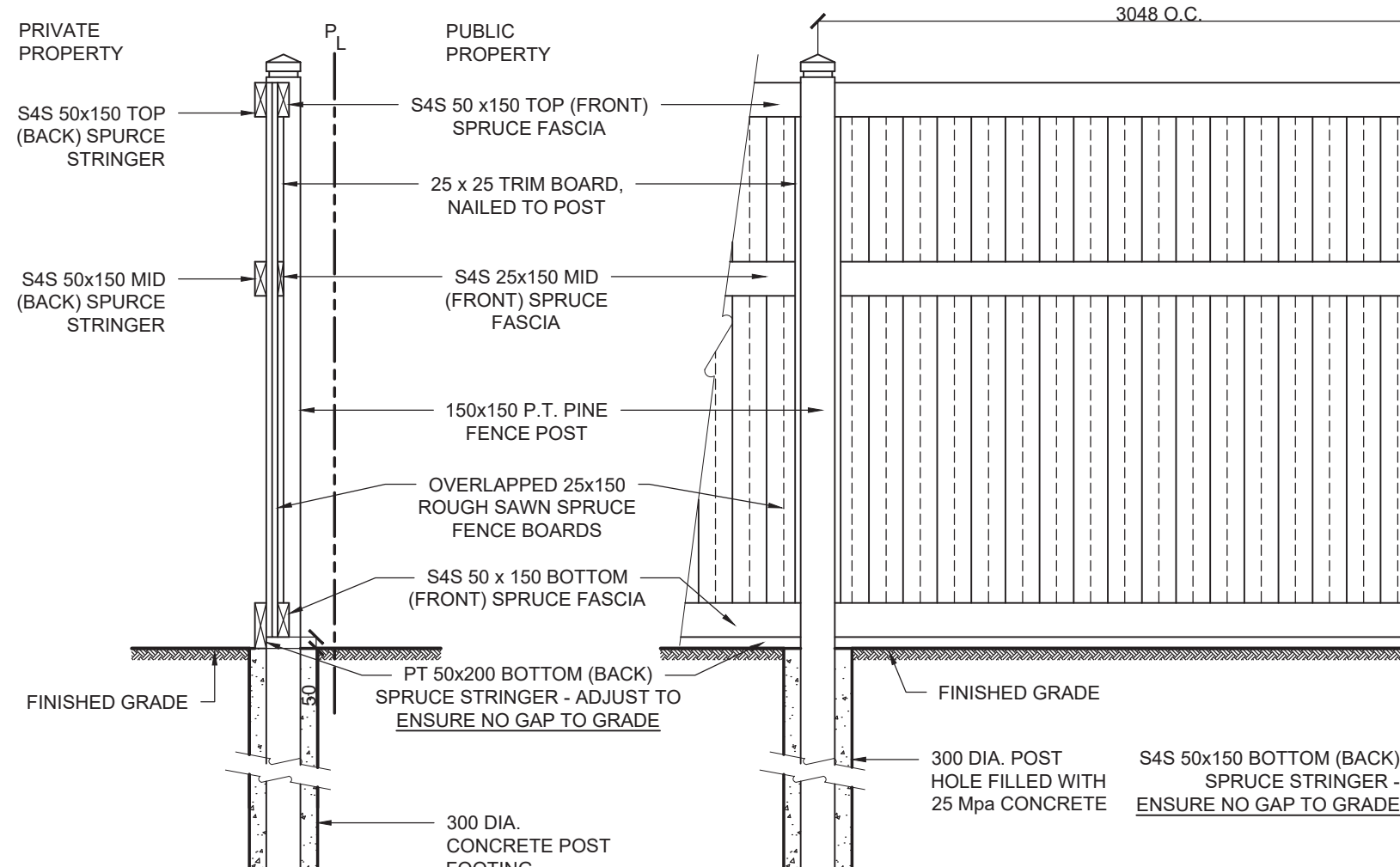
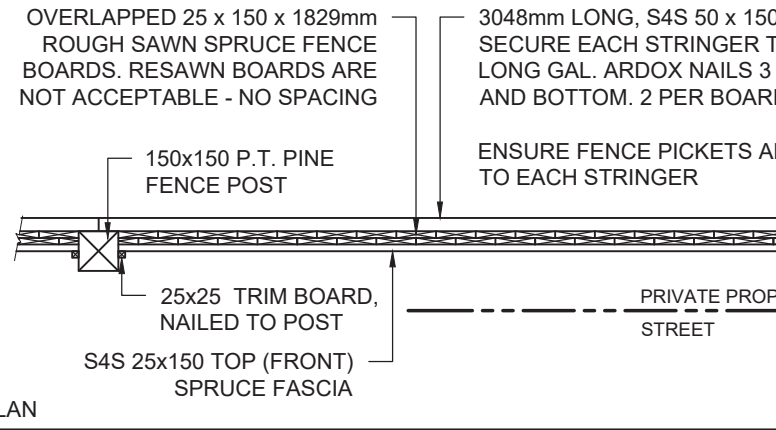

# Appendix “E” – Fence Details

---

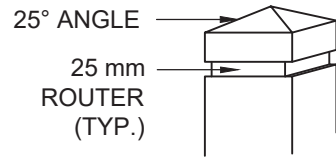

TYPICAL POST CAP DETAIL

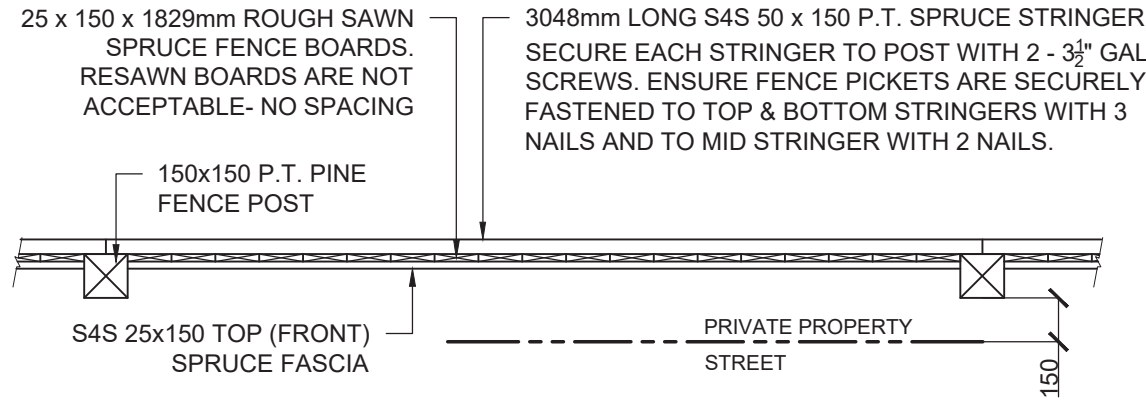

PLAN

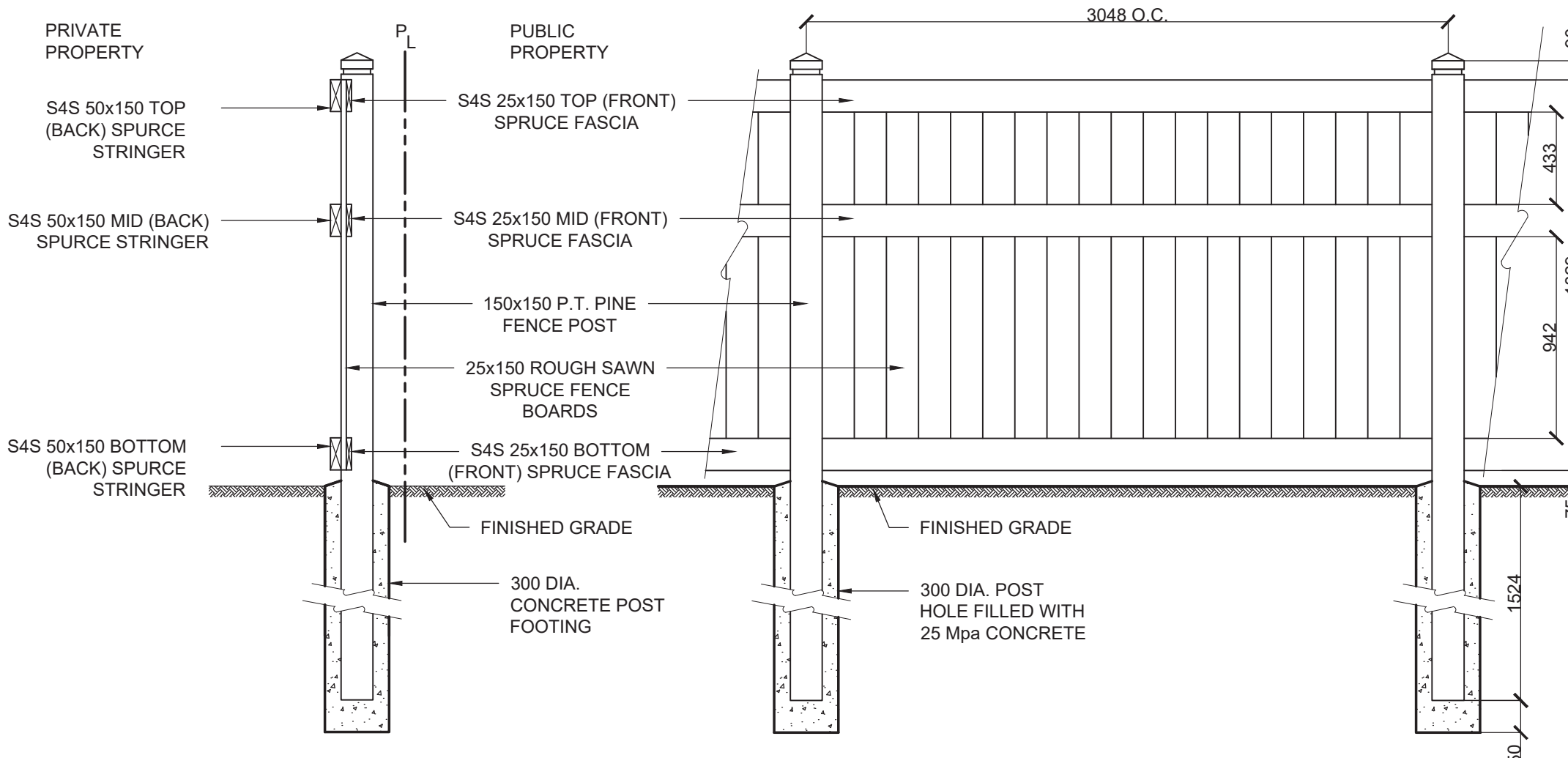

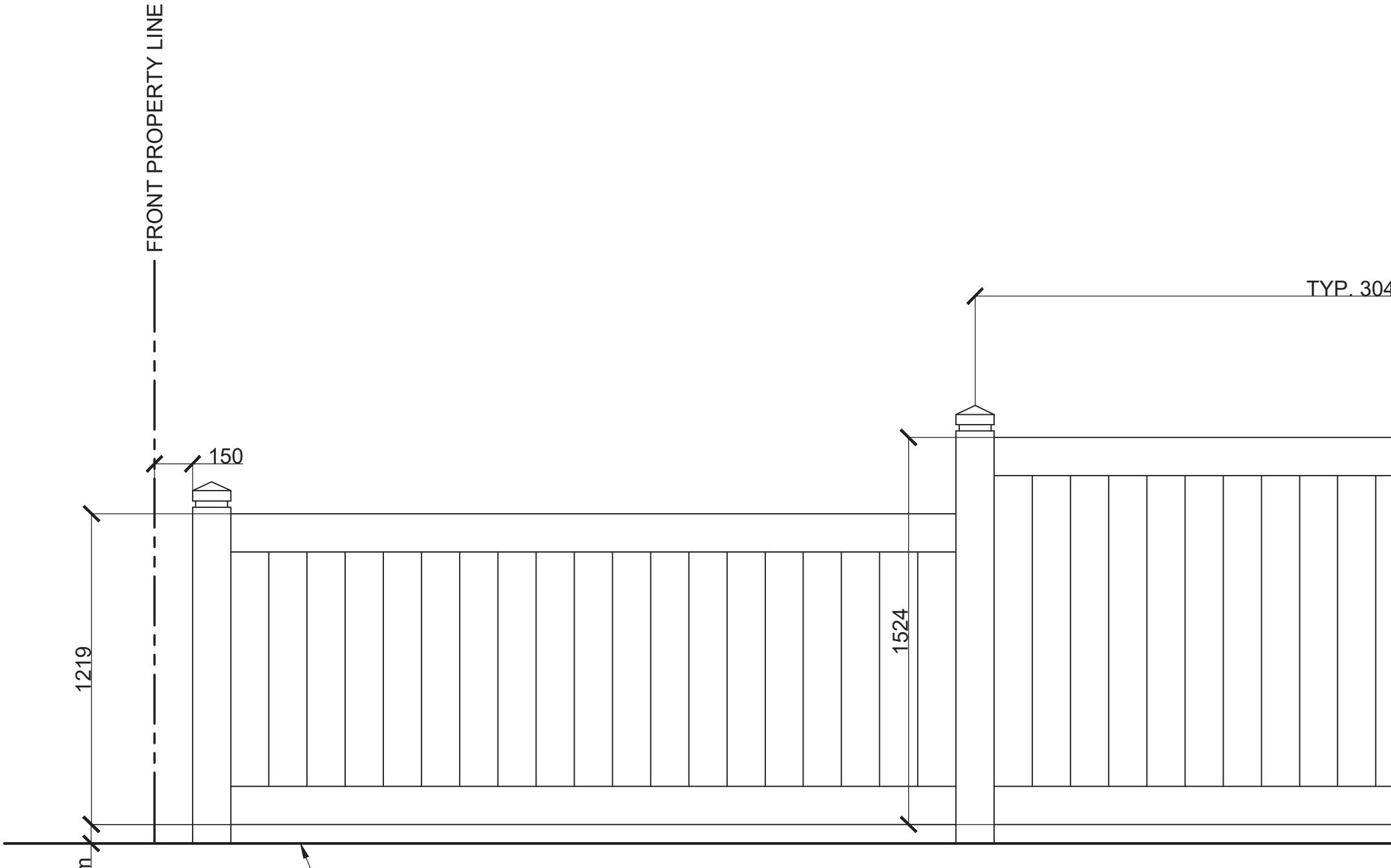

FRONT PROPERTY LINE

TYP. 304

150

1219

1524

m